

SPECIFICATIONS	
CONTACT CARRIER MATERIAL/COLOR	PVC/BLACK
MOLDED MATERIAL/COLOR	PVC/BLACK
CONTACT MATERIAL/PLATING	BRASS or COPPER/GOLD
COUPLING NUT MATERIAL/PLATING	BRASS/NICKEL
RATED CURRENT [A]	40 A
RATED VOLTAGE [V]	600 VAC
TEMPERATURE RATING	-40°C to +90°C (-40°F to +194°F)
PROTECTION CLASS	MEETS NEMA 1,3,4,6P AND IEC IP67, IP68, IP69K

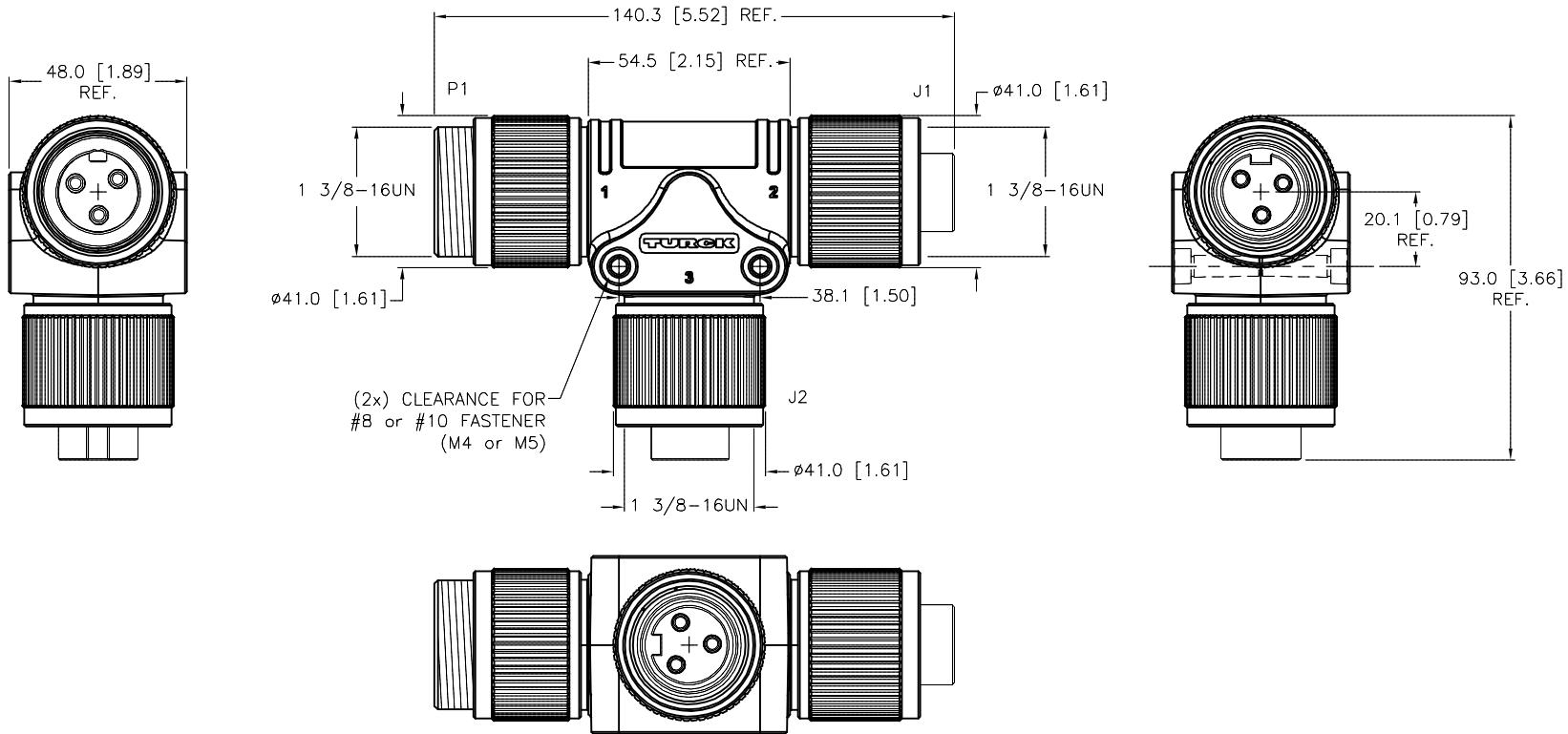

SOURCE DRAWING - FOR REFERENCE ONLY

CAUTION:
RISK OF ELECTRICAL SHOCK
DO NOT DISCONNECT UNDER LOAD

RELATED DOCUMENTS 1. 2. 3. 4.	3RD ANGLE PROJECTION 	THIS DRAWING IS CONFIDENTIAL AND THE PROPERTY OF TURCK INC. USE OF THIS DOCUMENT WITHOUT WRITTEN PERMISSION IS PROHIBITED.		3000 CAMPUS DRIVE MINNEAPOLIS, MN 55441 1-800-544-7769 (763) 553-7300 (763) 553-0708 fax www.turck.us	
		MATERIAL SEE SPECIFICATIONS	DRFT RDS APVD	DATE 11/07/08 SCALE 1=2.0	DESCRIPTION GSDM/2GKDM 30
FINISH SEE SPECIFICATIONS	ALL DIMENSIONS DISPLAYED ON THIS DRAWING ARE FOR REFERENCE ONLY	UNIT OF MEASUREMENT MILLIMETER [INCH]		IDENTIFICATION NO. U2-14749	
CONTACT TURCK FOR MORE INFORMATION		DO NOT SCALE THIS DRAWING		REV E	FILE: U2-14749

E	UPDATED CURRENT RATING	ER	04/25/19	69361
REV	DESCRIPTION	BY	DATE	ECO NO.